

Dimensions

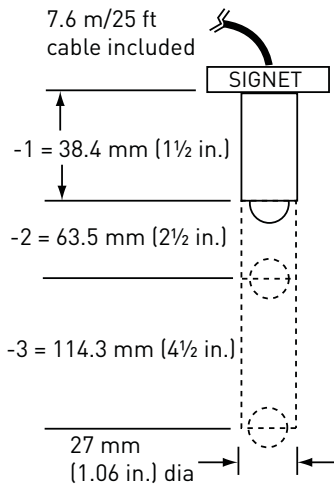

Application Tips

- Use the Conduit Adapter Kit to protect the cable-to-sensor connection when used in outdoor environments. See Accessories section.
- Use the Socket Weld or Weld-on Mini-Tap fittings for sensor installation in pressures up to 1500 psi (103 bar).
- The 525 can be used in intrinsically safe areas using an approved barrier between the sensor and instrument.

*Model 525

Ordering Notes

- 1) Each sensor option is used with a different fitting based on pipe size.
- 2) Fittings must be ordered separately.
- 3) See fittings section for more information.

Rotor Kit

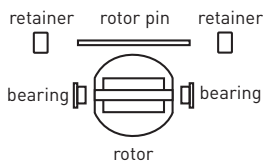

Please refer to Wiring, Installation, and Accessories sections for more information.

Specifications

General

Operating Range: 0.5 to 6 m/s
 (1.6 to 20 ft/s)
 Pipe Size Range: DN15 to DN300
 (1/2 to 12 in.)

Linearity: ±1% of max. range @ 25 °C (77 °F)
 Repeatability: ±0.5% of max. range @ 25 °C (77 °F)
 Min. Reynolds Number Required: 4500

Wetted Materials

Sensor Body: 316 SS (ACI type CF-8M per ASTM A351), DIN 17440
 Rotor Material: CB7Cu-1 Alloy
 Rotor Pin: Tungsten Carbide GRP 1 or 316 stainless steel
 Retainers (2): 316 stainless steel (1.4401)
 Rotor Bearings (2): Rulon® B (Fluoroloy/PTFE)
 Gasket: KLINGER®sil C-4401 (supplied with fitting)

Electrical

Frequency: 12 Hz per ft/s nominal,
 Amplitude: 5 to 8 mV p-p per Hz
 Source Impedance: 11.6 KΩ
 Cable Length: 7.6 m (25 ft), can be extended up to 60 m (200 ft)

Electrical (continued)

Cable Type: Cable (per foot) 2 cond. w/shield, 22 AWG

Max. Temperature/Pressure Rating

- Socket Weld or Weld-On Mini-Tap fittings: 103 bar (1500 psi @ safety factor 1.5) @ 149 °C (300 °F)
 - Strap-on Saddle fitting: 21 bar (300 psi) @ 66 °C (150 °F)
- Operating Temperature: -18 °C to 149 °C (0 °F to 300 °F)

See Temperature and Pressure graphs for more information.

Shipping Weight

P525-1/-1S	0.723 kg	1.6 lb
P525-2/-2S	0.774 kg	1.7 lb
P525-3/-3S	0.923 kg	2.0 lb

Standards and Approvals

- FM Class I (Group A, B, C, D), II (Group E, F, G), III, Division 1 (Groups A-G)
- RoHS compliant
- Manufactured under ISO 9001 for Quality and ISO 14001 for Environmental Management

Ordering Information

Sensor Part Number	
P525	Metalex Flow sensor for high pressures and temperatures
	Sensor Style
-1	used with 1/2 to 1 inch socket-weld mini-tap fittings**
-2	used with 1/4 to 12 inch weld-on mini-tap fittings**
-3	used with 2 to 12 inch strap-on saddle fittings**
	Rotor Pin Material
-	Tungsten Carbide
S	316 Stainless Steel
P525	-1 Example Part Number

**See Fittings section.

Mfr. Part No.*	Code	Mfr. Part No.*	Code
P525-1	198 801 494	P525-1S	159 000 963
P525-2	198 801 495	P525-2S	159 000 964
P525-3	198 801 496	P525-3S	159 000 965

Accessories and Replacements Parts

Mfr. Part No.	Code	Description
P52509	198 801 501	Rotor kit (rotors, stainless steel pin, bearings, retainers)
P52509-2	159 000 480	Rotor kit (rotors, tungsten carbide pin, bearings, retainers)
P52504-1	198 801 500	Rotor pin, Stainless Steel (1.4401)
P52504-2	198 820 023	Rotor pin, Tungsten Carbide
P52618	159 000 493	Gasket
P52503	198 820 013	Bearing, Rulon® B (Fluoroloy/PTFE)
P52527	159 000 481	Retainers, Stainless Steel
P52628	159 000 504	Fitting cap kit (cap and gasket)
P51589	159 000 476	Conduit adapter kit
5523-3222	159 000 393	Cable (per foot) 2 cond. w/shield, 22 AWG
6402-9001	159 001 486	Intrinsic safety barrier (2 required)